

ST-10P | SUBMERSIBLE PUMPS 100 MM



302ST-10P07 • 302ST-10P10 • 302ST-10P14 • 302ST-10P20

Impellers are floating type made of Noryl® for a superior sand handling. Together with glass filled polycarbonate diffusers make the super strong pumps for maximum wear and abrasive resistance.

APPLICATION

- Water supply
- Agricultural irrigation
- Pressure boosting

OPERATING CONDITIONS

- Rated speed - 2850 rpm
- Delivery - 6.6 m³/h
- Head - 139 m
- Sand content - 150 g/m³
- Motor power - 0.37 kW – 1.1 kW

MATERIALS

- Discharge head - Noryl
- Check valve - POM
- Bearing spider - Glass Filled Polycarbonate
- Diffuser - Glass Filled Polycarbonate
- Bowl - AISI 304 Stainless Steel
- Impeller - Noryl
- Strainer - Polypropylene
- Pump casing - AISI 304 Stainless Steel
- Shaft sleeve - AISI 304 Stainless Steel

PUMP TYPE	DIMENSIONS (mm)			N.W (kg)
	A	B	C	
302ST-10P07	344	RP or NPT 1¼"	98	2.8
302ST-10P10	397		98	3.3
302ST-10P14	467		98	3.9
302ST-10P20	573		98	4.9

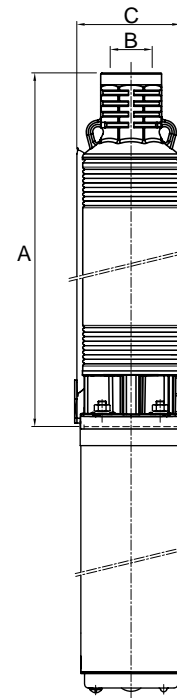

PUMP TYPE	MOTOR		Q = DELIVERY								
			ℓ/min 0	15	20	25	30	35	40	45	50
	kW	HP	m³/h 0	0.9	1.2	1.5	1.8	2.1	2.4	2.7	3.0
			H = TOTAL HEAD IN METERS								
302ST-10P07	0.37	0.5	46	43	42	39	36	33	29	26	22
302ST-10P10	0.55	0.75	67	64	61	58	54	49	43	36	28
302ST-10P14	0.75	1.0	92	86	83	79	74	67	60	52	42
302ST-10P20	1.1	1.5	139	131	127	120	111	101	90	75	60

SUBMERSIBLE PUMP COMBO 0.55 kW

302ST-10P10C

Speroni and Stairs submersible pump combo pack. The Speroni ST-P Submersible Borehole pump range covers a wide range of pumping duties for agricultural and domestic applications. Floating NORYL type impellers require less starting torque and are less affected by sand or other abrasive materials. The discharge head and motor adaptor are made from Noryl for superior strength and durability.

- 1 - 302ST-10P10 Stairs Submersible Pump
- 2 - Stairs 230 V Submersible Motor
- 3 - 50 m Submersible Cable
- 4 - Control Box
- 5 - Rope
- 6 - HDPE Base Plate 32 mm
- 7 - 2 x Compression Male Adaptors 40 mm x 1-¼"
- 8 - 5 m Cabtyre & 3 Point Plug

Everything is pre-assembled, cabled jointed to the motor, only the 32 mm HDPE pipe must be supplied for installation. To be installed at a maximum depth of 50 m.

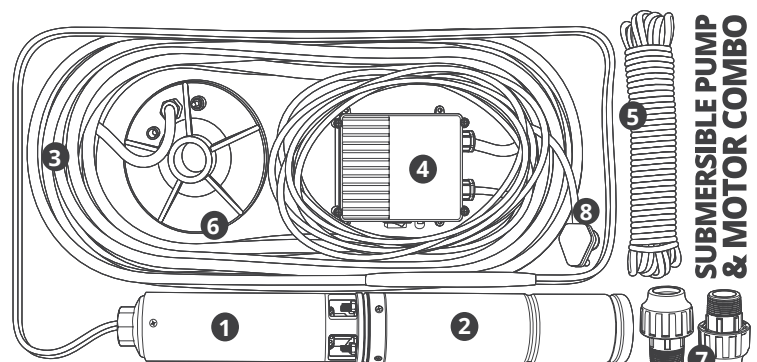

**Not included in kit: 32 mm pipe, inducer sleeve, above ground fittings

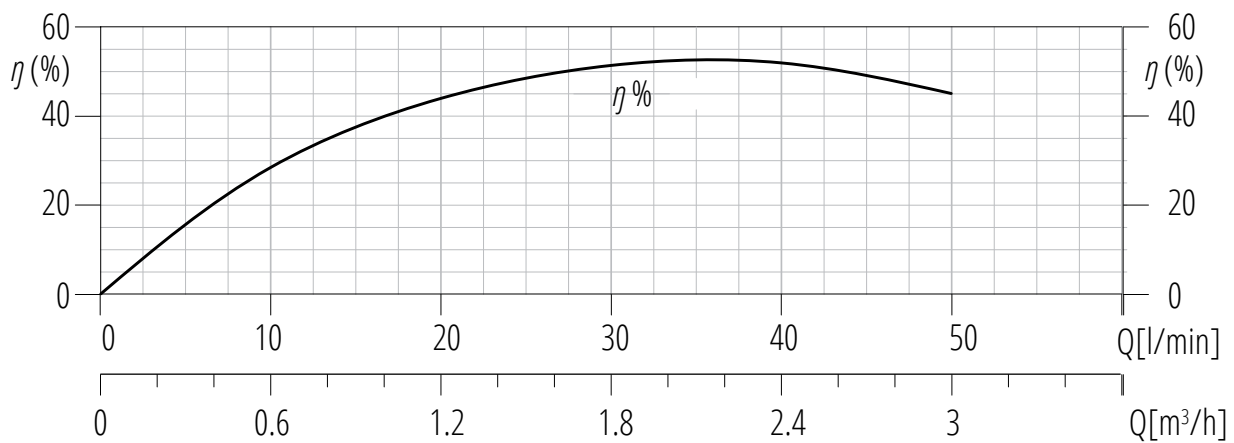
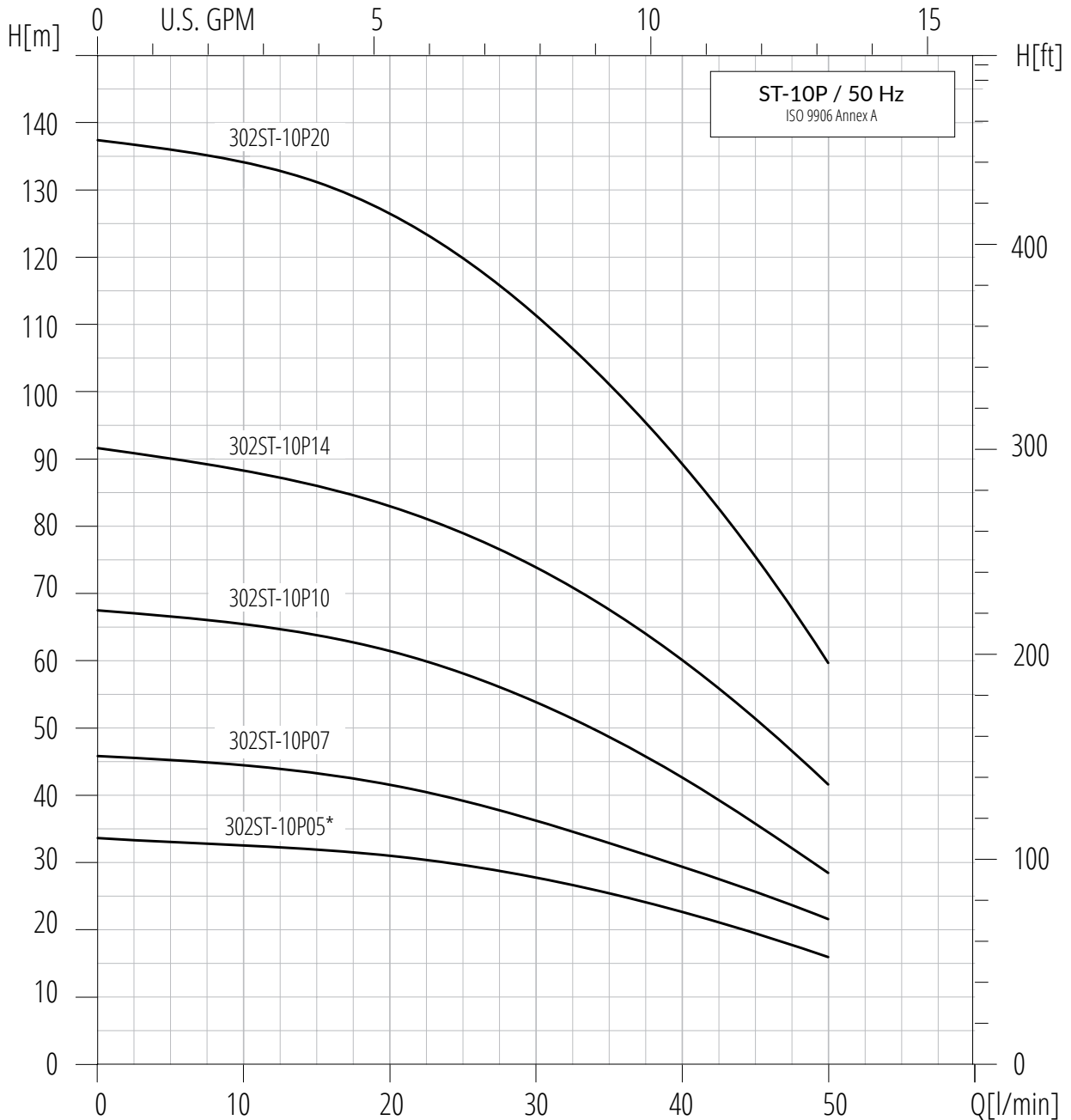

ST-13P | SUBMERSIBLE PUMPS 100 MM



302ST-13P05 • 302ST-13P08 • 302ST-13P11 • 302ST-13P16

Impellers are floating type made of Noryl® for a superior sand handling. Together with glass filled polycarbonate diffusers make the super strong pumps for maximum wear and abrasive resistance.

APPLICATION

- Water supply
- Agricultural irrigation
- Pressure boosting

OPERATING CONDITIONS

- Rated speed - 2850 rpm
- Delivery - 6.6 m³/h
- Head - 139 m
- Sand content - 150 g/m³
- Motor power - 0.37 kW – 1.1 kW

MATERIALS

- Discharge head - Noryl
- Check valve - POM
- Bearing spider - Glass Filled Polycarbonate
- Diffuser - Glass Filled Polycarbonate
- Bowl - AISI 304 Stainless Steel
- Impeller - Noryl
- Strainer - Polypropylene
- Pump casing - AISI 304 Stainless Steel
- Shaft sleeve - AISI 304 Stainless Steel

PUMP TYPE	DIMENSIONS (mm)			N.W (kg)
	A	B	C	
302ST-13P05	309	RP or NPT 1¼"	98	2.5
302ST-13P08	362		98	2.9
302ST-13P11	414		98	3.4
302ST-13P16	503		98	4.2

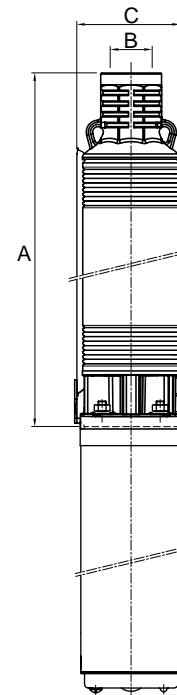

PUMP TYPE	MOTOR		Q = DELIVERY									
			ℓ/min 0	20	25	30	35	40	45	50	60	70
	kW	HP	m ³ /h 0	1.2	1.5	1.8	2.1	2.4	2.7	3.0	3.6	4.2
			H = TOTAL HEAD IN METERS									
302ST-13P05	0.37	0.5	34	32	31	30	29	27	25	23	18	11
302ST-13P08	0.55	0.75	54	51	50	49	46	43	41	38	30	19
302ST-13P11	0.75	1.0	72	68	66	64	61	58	54	49	38	26
302ST-13P16	1.1	1.5	106	101	98	95	89	83	77	70	54	33

SUBMERSIBLE PUMP COMBO 1.1 kW

302ST-13P11C • 302ST-13P16C

Speroni and Stairs submersible pump combo pack. The Speroni ST-P Submersible Borehole pump range covers a wide range of pumping duties for agricultural and domestic applications. Floating NORYL type impellers require less starting torque and are less affected by sand or other abrasive materials. The discharge head and motor adaptor are made from Noryl for superior strength and durability.

- 1- 302ST-13P11 / 302ST-13P16 Stairs Submersible Pump
- 2- Stairs 230 V Submersible Motor
- 3- • 50 m Submersible Cable (302ST-13P11C)
• 70 m Submersible Cable (302ST-13P16C)
- 4- Control Box
- 5- Rope
- 6- HDPE Base Plate 40 mm
- 7- 2 x Compression Male Adaptors
- 8- 5 m Cabtyre & 3 Point Plug

Everything is pre-assembled, cabled jointed to the motor, only the 32 mm HDPE pipe must be supplied for installation. To be installed at a maximum depth of 50 m.

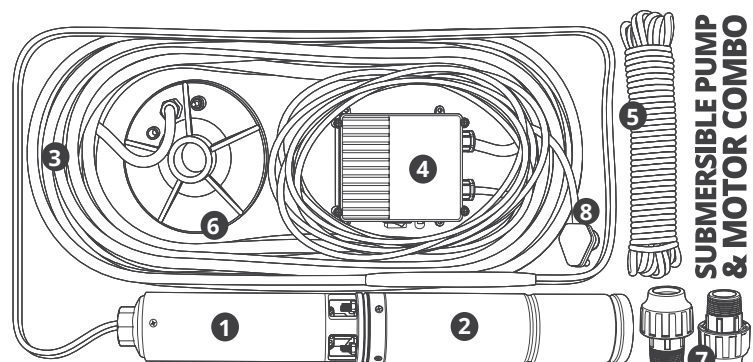

**Not included in kit: 32 mm pipe, inducer sleeve, above ground fittings

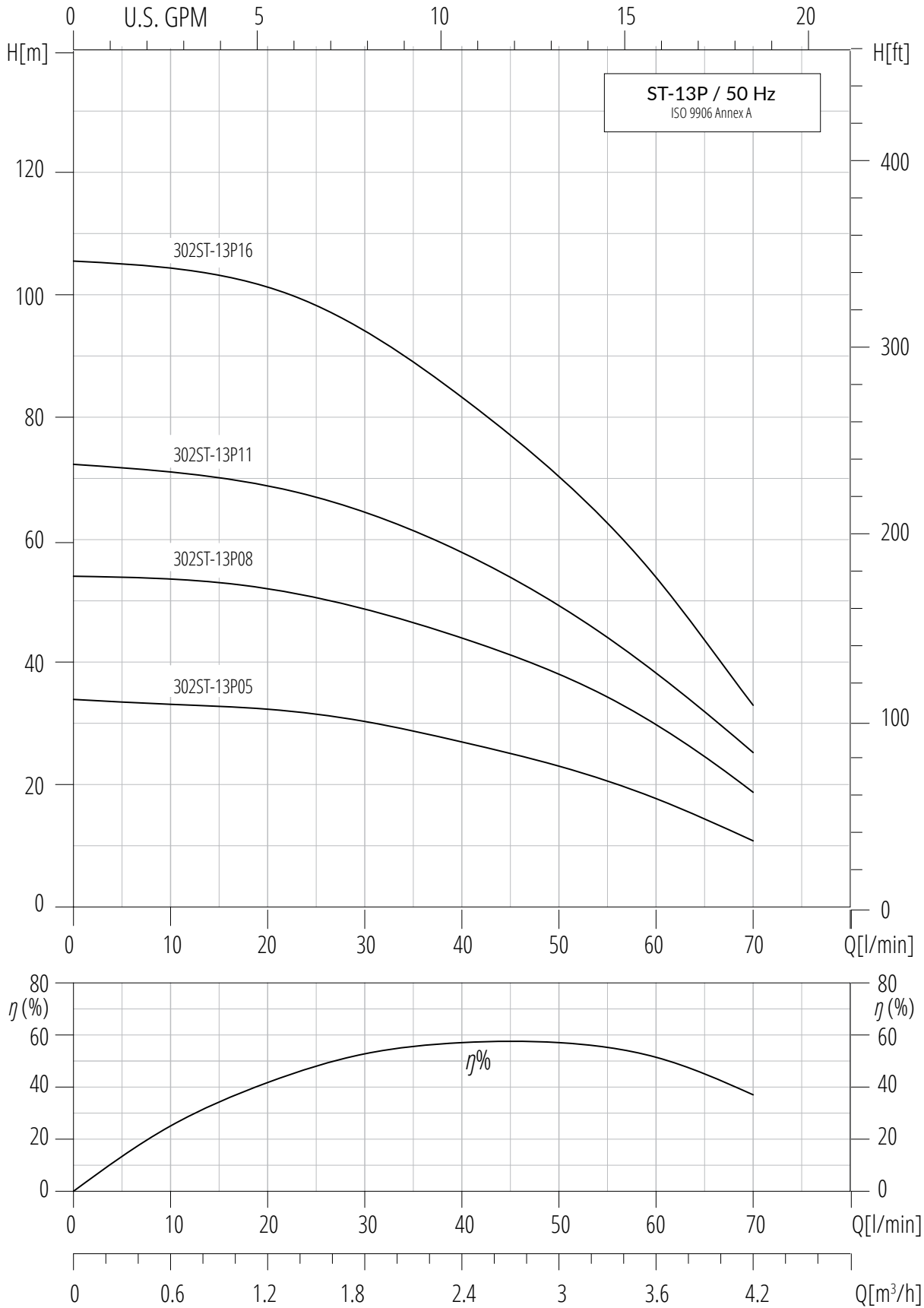

ST-5P | SUBMERSIBLE PUMPS 100 MM



302ST-05P10 • 302ST-05P13 • 302ST-05P19

Impellers are floating type made of Noryl® for a superior sand handling. Together with glass filled polycarbonate diffusers make the super strong pumps for maximum wear and abrasive resistance.

APPLICATION

- Water supply
- Agricultural irrigation
- Pressure boosting

OPERATING CONDITIONS

- Rated speed - 2850 rpm
- Delivery - 6.6 m³/h
- Head - 139 m
- Sand content - 150 g/m³
- Motor power - 0.37 kW – 0.55 kW

MATERIALS

- Discharge head - Noryl
- Check valve - POM
- Bearing spider - Glass Filled Polycarbonate
- Diffuser - Glass Filled Polycarbonate
- Bowl - AISI 304 Stainless Steel
- Impeller - Noryl
- Strainer - Polypropylene
- Pump casing - AISI 304 Stainless Steel
- Shaft sleeve - AISI 304 Stainless Steel

PUMP TYPE	DIMENSIONS (mm)			N.W (kg)
	A	B	C	
302ST-05P10	324	RP or NPT 1¼"	98	3.3
302ST-05P13	377		98	3.3
302ST-05P19	481		98	4.7

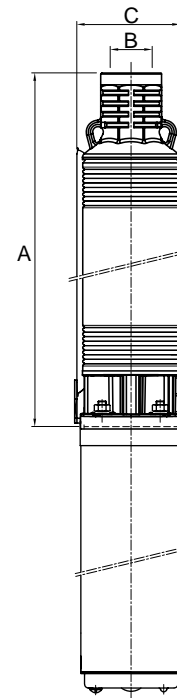

PUMP TYPE	MOTOR		Q = DELIVERY					
			ℓ/min 0	5	10	15	20	25
	kW	HP	m³/h 0	0.3	0.6	0.9	1.2	1.5
302ST-05P10	0.37	0.5	67	63	65	46	33	18
302ST-05P13	0.37	0.5	86	78	70	56	42	23
302ST-05P19	0.55	0.75	126	118	105	86	60	30

SUBMERSIBLE PUMP COMBO 0.37 kW

302ST-05P13C

Speroni and Stairs submersible pump combo pack. The Speroni ST-P Submersible Borehole pump range covers a wide range of pumping duties for agricultural and domestic applications. Floating NORYL type impellers require less starting torque and are less affected by sand or other abrasive materials. The discharge head and motor adaptor are made from Noryl for superior strength and durability.

- 1 - 302ST-05P13 Stairs Submersible Pump
- 2 - Stairs 230 V Submersible Motor
- 3 - 50 m Submersible Cable
- 4 - Control Box
- 5 - Rope
- 6 - HDPE Base Plate 32 mm
- 7 - 2 x Compression Male Adaptors 40 mm x 1-¼"
- 8 - 5 m Cabtyre & 3 Point Plug

Everything is pre-assembled, cabled jointed to the motor, only the 32 mm HDPE pipe must be supplied for installation. To be installed at a maximum depth of 50 m.

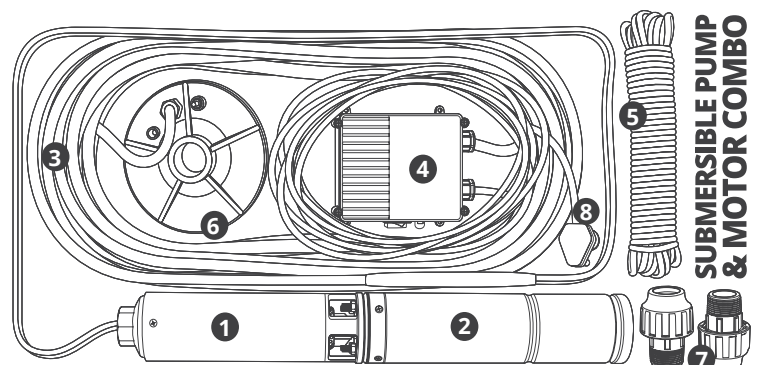

**Not included in kit: 32 mm pipe, inducer sleeve, above ground fittings

